



Magneto Indoor Magneto

- Easy to change the poster
- Front loading graphic change
- Ultra flat / no snap profile
- Long life fluorescent lamps
- Even spread of light
- Low energy consumption
- Single- or double sided
- Indoor usage
- Easy to install / easy to handle
- Long life, high quality
- Possible branding with logo
- Modern and neutral design

Noventis viscom
Signs and Displays

Noventis Viscom SA
Chemin du Pont-du-Centenaire 109,
CH-1228 Plan-les-Ouates
T 022 738 10 31
F 022 738 10 34

www.noventis-viscom.com
info@noventis-viscom.com



posterwissel met zuignap
changement de l'affiche avec ventouse
poster change with suction cup
Posterwechsel mit Saugnapf

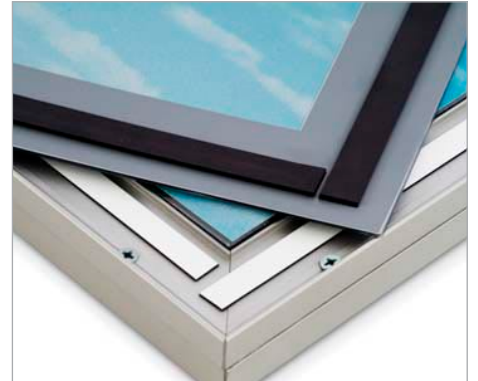

magneetstrips
bande magnétique
magnetic strips
Magnetband



montagegaten
trous de montage
mounting holes
Befestigungslöcher



voorzetvel met gezeefdrukte rand
feuille de protection avec bord sérigraphié
protection panel with screen printed border
Schutzfolie mit Siebdruckrand



optie: ophangsetje met staalkabel
option: kit de suspension avec câble en acier
option: suspension kit with steel cable
Option: Aufhängesystem mit Stahlseil



stekker
connecteur
connector
Stecker

SPECIFICATIES SPÉCIFICATIONS SPECIFICATIONS SPEZIFIKATIONEN



1	centrale lichtplaat (PMMA) diffuseur (PMMA) edge lit panel (PMMA) Lichtstreuplatte (PMMA)	2	magneetstrips bande magnétique magnetic strips Magnetband
3	basisprofiel (geanodiseerd alu) profilé de base (alu anodisé) base profile (alu anodised) Trägerprofil (Alu eloxiert)	4	TL-lamp (T5) tube TL (T5) fluorescent tube (T5) Leuchtstoffröhre (T5)
5	rugpaneel (alu 1 mm) panneau de dos (alu 1mm) back panel (alu 1 mm) Rückwand (1mm alu)	6	afdekprofiel (geanodiseerd alu) profilé couvrant (alu anodisé) cover profile (alu anodised) Abdeckprofil (Alu eloxiert)
7	beschermfolie (pc anti-reflex) feuille de protection (pc anti-reflet) protection panel (pc anti-glare) Schutzfolie (pc antireflectierend)	8	lampreflectorprofiel (alu) profilé de réflecteur (alu) reflector profile (alu) Reflektorprofil (Alu)

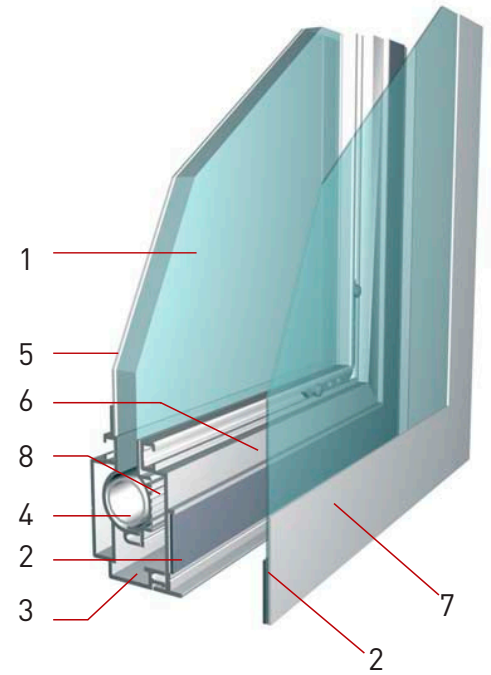

	MAGNETO
VISIBLE SIZE	poster size - 24 mm
OVERALL SIZE	poster size + 60 mm
BORDER PRINT	40 mm
	POWDER COATED PROFILES ON DEMAND

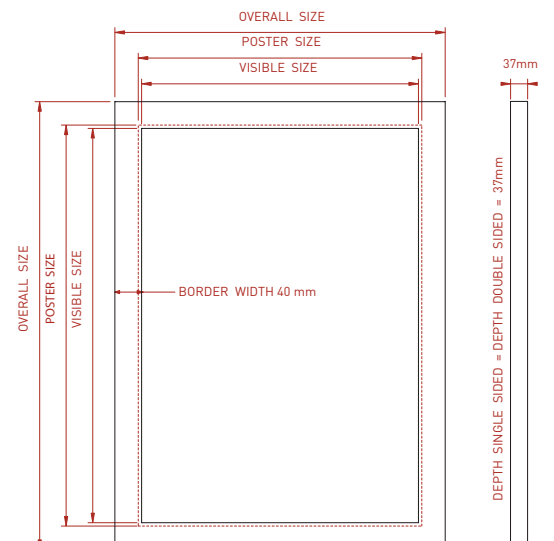

HANDLEIDING MODE D'EMPLOI MANUAL ANLEITUNG



PLAATSING
MONTAGE
MOUNTING
MONTAGE

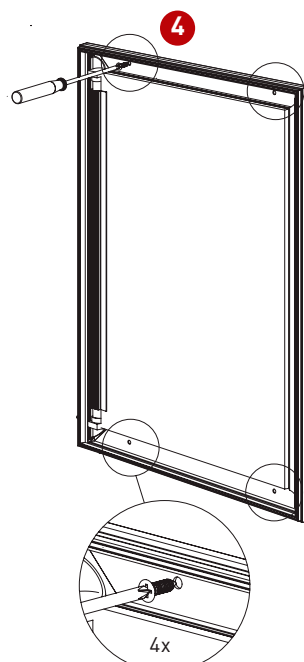
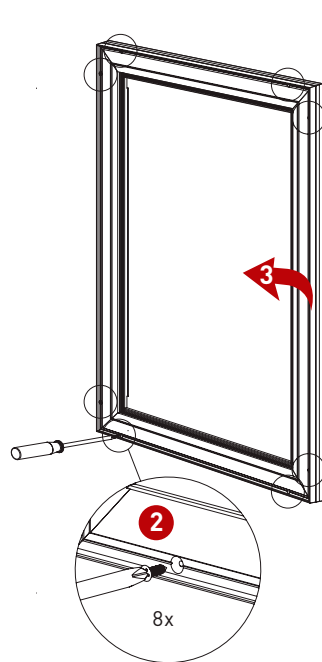
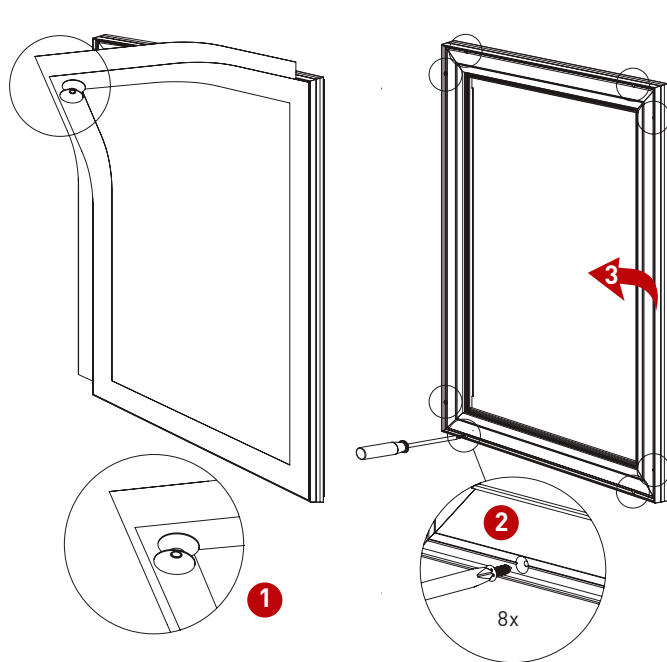

POSTERWISSEL
CHANGEMENT DE L'AFFICHE
POSTER CHANGE
POSTERWECHSEL

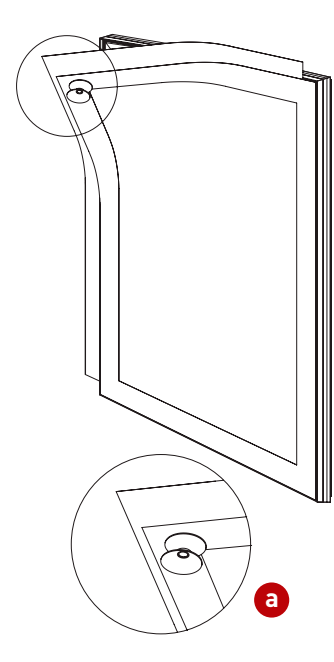

NL

PLAATSING

1. Verwijder het voorzetvel met behulp van de zuignap.
2. Draai de 8 schroefjes met afstandhouders los.
3. Neem het bovenkader weg.
4. Bevestig het product tegen de wand via de 4 voorziene gaten in het onderprofiel.

POSTERWISSEL

- a. Verwijder het voorzetvel met behulp van de zuignap.
- b. Verwissel de poster en plaats het voorzetvel terug.

FR

MONTAGE

1. Otez la feuille de protection avec la ventouse.
2. Dévissez les 8 vis.
3. Otez le cadre couvrant.
4. Vissez le cadre contre le mur par les 4 trous dans le profilé de base.

CHANGEMENT DE L' AFFICHE

- a. Otez la feuille de protection avec la ventouse.
- b. Changez l'affiche et repositionnez la feuille de protection.

EN

MOUNTING

1. Remove the protection panel with the suction cup.
2. Unscrew the 8 screws.
3. Remove the top frame.
4. Fix the profile against the wall using the 4 holes in the bottom profile.

POSTER CHANGE

- a. Remove the protection panel with the suction cup.
- b. Change the poster and put the protection panel back in position.

DE

MONTAGE

1. Schutzfolie entfernen mit Hilfe des Saugnapfs.
2. Schrauben Sie den Aluabdeckrahmen los (8 Schrauben).
3. Aluabdeckrahmen entnehmen.
4. Das Trägerprofil durch die 4 Löcher an die Wand schrauben.

POSTERWECHSEL

- a. Schutzfolie entfernen mit Hilfe des Saugnapfs.
- b. Poster wechseln und Schutzfolie wieder genau auflegen.

TOEPASSINGEN
APPLICATIONS
APPLICATIONS
ANWENDUNGEN



TOEPASSINGEN
APPLICATIONS
APPLICATIONS
ANWENDUNGEN

